

## Scinor® SMT600-P80 Pressurized Ultrafiltration Module

One of the largest pressurized ultrafiltration modules in the market

Scinor SMT600 series ultrafiltration modules utilizing our state-of-the-art Thermally Induced Phase Separation (TIPS) PVDF membranes provide the highest permeability, mechanical strength, and chemical tolerance in the industry. These modules are ideal for use in potable water, wastewater, desalination, and industrial applications. The SMT600-P80 retrofits major membrane vendor installations giving end-users a choice when replacing membranes.

The large and reliable SMT600-P80 pressurized ultrafiltration module is suitable for large-scale water treatment plants due to high permeability and high fiber packing density which reduces overall system footprint and lowers system capital cost.

The SMT600-P80 is an outside-in configuration module that operates in dead-end or cross-flow mode depending on specifics of the application. Cleaning processes used are simple backwash, maintenance clean, and Clean-in-Place.

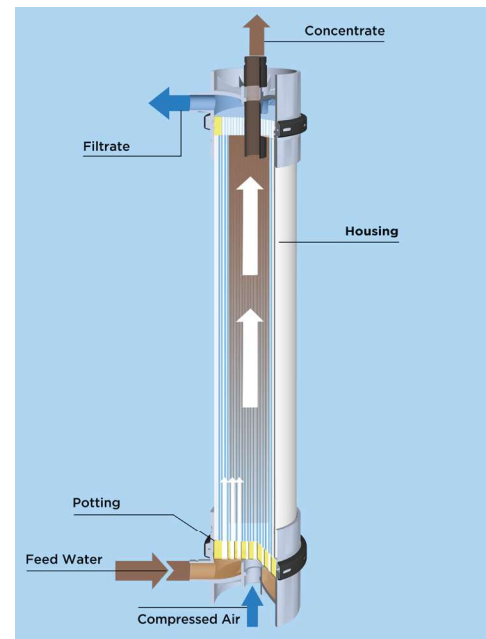
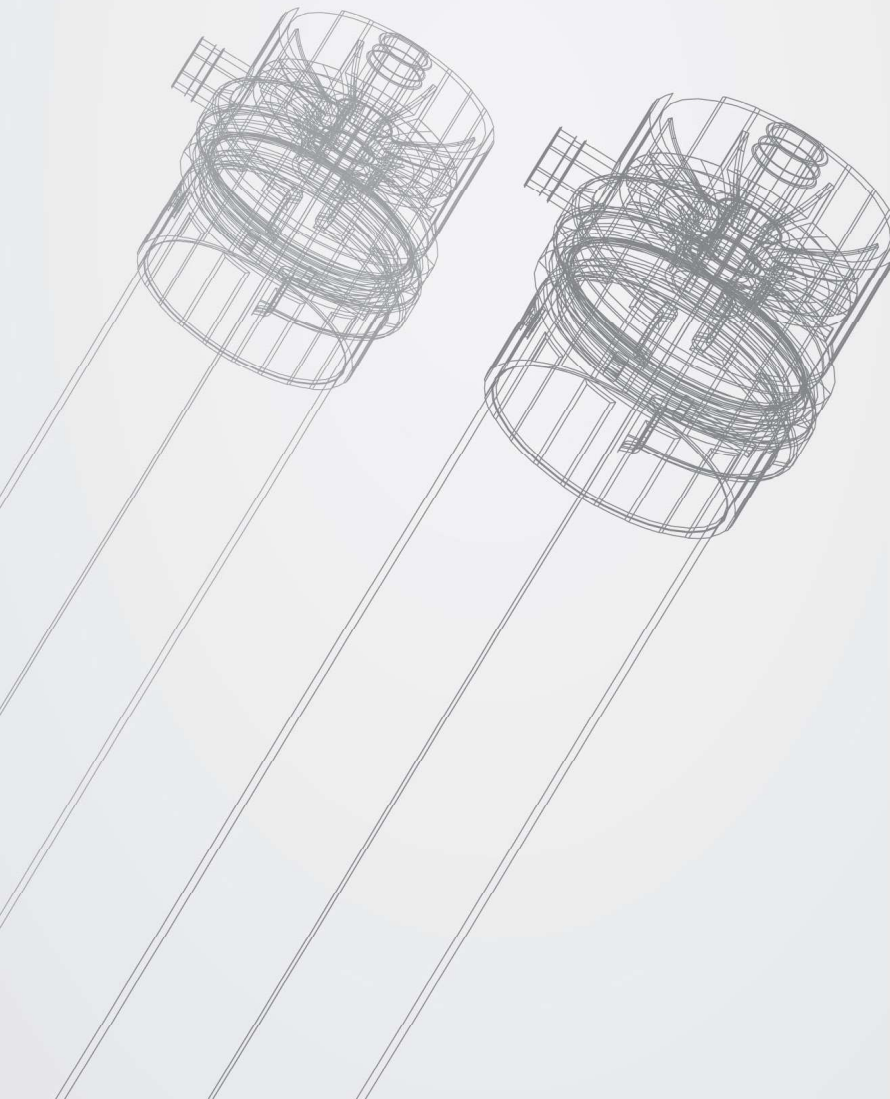

### Product Advantages

#### Excellent Filtered Water Quality

- Tight 0.1 µm pore size distribution
- Low fiber breakage rate

#### Long Operational Life

- High mechanical strength and durability
- >5000 mg/L Sodium Hypochlorite tolerance

#### Low Requirements for Pretreatment

- Outside-in configuration
- Optimal flow channel

#### Low Operating and Maintenance Requirements

- Low energy and chemical consumption due to higher permeability
- Automatic operation

#### Low Capital Cost

- High flux rates on all water sources

#### Small Footprint

- High hollow-fiber packing density
- Large 80m<sup>2</sup> module building blocks

#### Italhydro - Italy

36016, Thiene (VI)  
Italy  
office@italhydro.com

Please visit [italhydro.com](http://italhydro.com) for further information.



Retrofit modules available for all major membrane suppliers

Scinor® Module	Part Number	SMT600-P80
	Fiber Material	Polyvinylidene Fluoride (PVDF)
	Effective Area	861 ft <sup>2</sup> (80 m <sup>2</sup> )
	Nominal Pore Size	0.1 μm
	Fiber ID/OD	0.7 mm/1.3 mm
	Geometry	Φ 225 mm × 2360 mm
	Port Size	DN50
	Housing/Head Material	U-PVC/ABS
	Potting Material	Epoxy Resin
Operating Parameters	Temperature	33-104 ° F (1-40 C)
	pH Range	1-11 Continuous
	Max. NaClO	5000 mg/L
	Backwash Flux	30-70 gfd (50-120 l/mh)
	Air Scour Flow	3.1-7.5 scfm/module (5-12 Nm <sup>3</sup> /hr/module)
	CIP pH Range	1-13
	Max. Feed Pressure	60 psi (0.4 MPa)
	Max. TMP	45 psi (0.3 MPa)
	Operating TMP	3-22 psi (0.02-0.15 MPa)
	Max. Air Scour Pressure	36 psi (0.25 MPa)
	Max. Backwash Pressure	36 psi (0.25 MPa)
Filtered Water Performance	Turbidity	≤0.1 ntu
	Silt Density Index	≤3
	E.Coli Removal	non-detect



Drinking Water



Wastewater

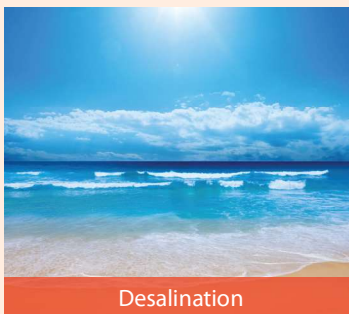

Desalination



Industrial